

ASCENDO

C7

USER'S MANUAL

Contents

1	OVERVIEW	3
1.1	Overall Picture	3
1.2	Application	3
1.3	Safety Warning	3
1.4	Operating modes	4
1.5	Technical Data	4
2	INSTALLATION	5
2.1	Demands of speaker location	5
2.2	Mounting	5
3	SETTING UP AND TRANSPORT	5
4	CONNECTION	5
5	TOS-UNIT	6
6	CLEANING	6

ASCENDO GMBH

HÖLDERLINWEG 6
73257 KÖNGEN
GERMANY

Phone: 0049 (0) 7024 9288 84

Fax: 0049 (0) 7024 9288 64

MAIL: MAIL@ASCENDO.DE

www.ascendo.de

1 Overview

The ASCENDO C7 is a four-way Loudspeaker (TOS ON) constructed with ASCENDO's SASB-Technology and ASCENDO TOS-Unit.

1.1 Overall Picture

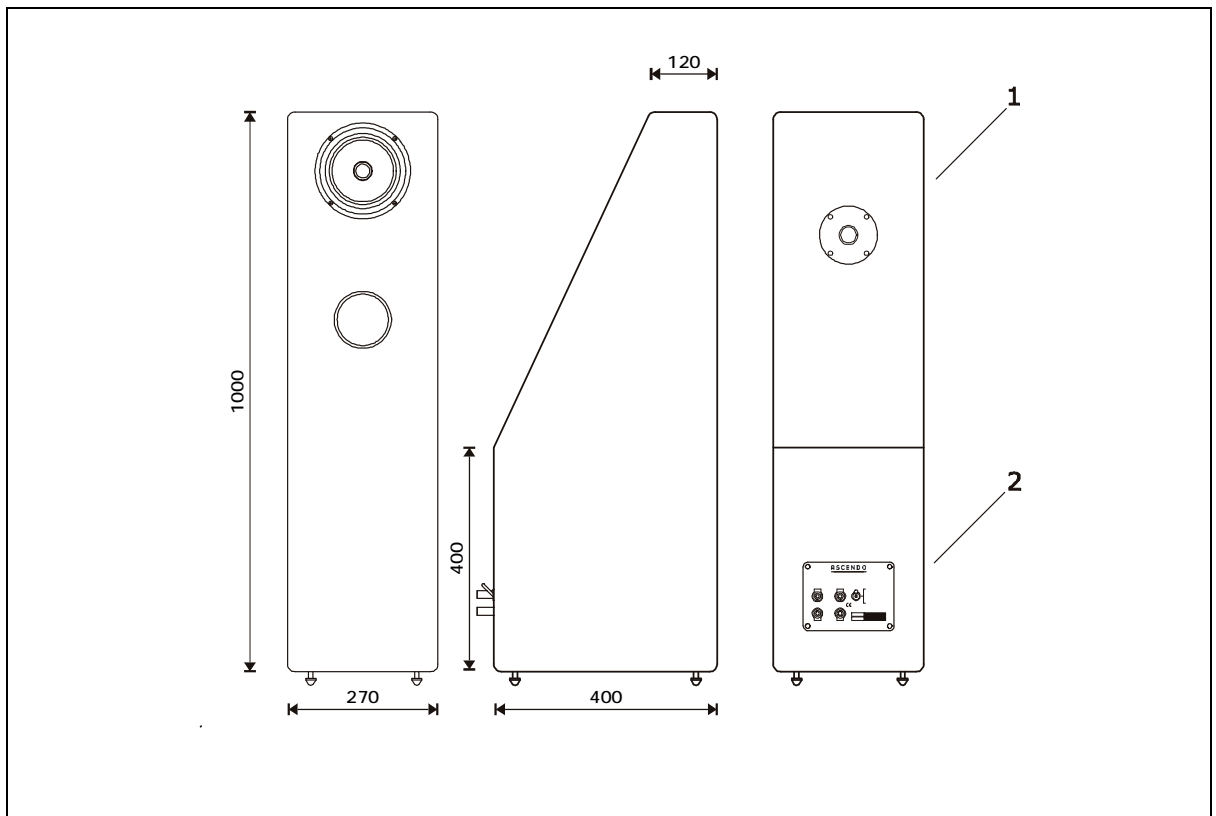

- 1 TOS-Unit
- 2 Terminal

1.2 Application

The ASCENDO Loudspeaker C7 intended for use in small to mid-size rooms (< 100 m²).

You can use the C7 with amplifiers in the power range of 10 W to 350 W.

1.2 Safety Warning



Warning

This Loudspeaker can produce high sound-levels. This may damage your ears permanently!

1.4 Operating modes

You can use the C7 a single-amp setup (one power amplifier for high- and low-frequency unit) or in a bi-amp setup (one power amplifier for the low-frequency-unit, one for the high-frequency unit).

If your setup is single-amp you must bridge the high- and low-frequency unit with a high quality speaker cable.

1.5 Technical Data

Principle	Three-Way with SASB bass unit (TOS Off) (current damped outer driver with semi symmetrical band pass) Four-Way with SASB bass unit (TOS ON)
Dimensions (W/H/D)	27 / 100 / (40-12)
Weight	30 Kg
Frequency Range	28 Hz (-3 dB) – 25.000 Hz
Power	350 W Program (min.)
Impedance	6 Ohm
Sensitivity	88 db / 1W/m
Outer Chassis (Coax)	COAX • 25 mm Neodymium-fabric-tweeter • 17 cm Woofer with XP cone
Inner Chassis	21 cm Chassis, Kevlar cone
TOS Chassis	27 mm Magnesium tweeter no Ferrofluid
TOS function	switch able An: TOS Unit / Dipole On Aus: TOS Unit / Dipole Off
Sockets	Bi-Wiring

Technical data may change without notice

2. Setting up and Transport

2.1 Demands of speaker location

- Use the C7 in closed rooms only. Do not expose the speaker to high humidity, direct water and direct sunbeam.
- Take care of a minimum distance of 2 m of the speaker to monitors (TV, computer) and magnetic devices (audio/video-cassettes, floppy-disks, etc.).

WARNING

There may be a slight permanent imprint in soft floor-material.

2.2 Transport

Before any movement of the speaker switch of the power amplifiers and disconnect all cables of the C7.

WARNING

Don't try to move or transport the C7 alone! The weight affords at least two persons.

4. Connection

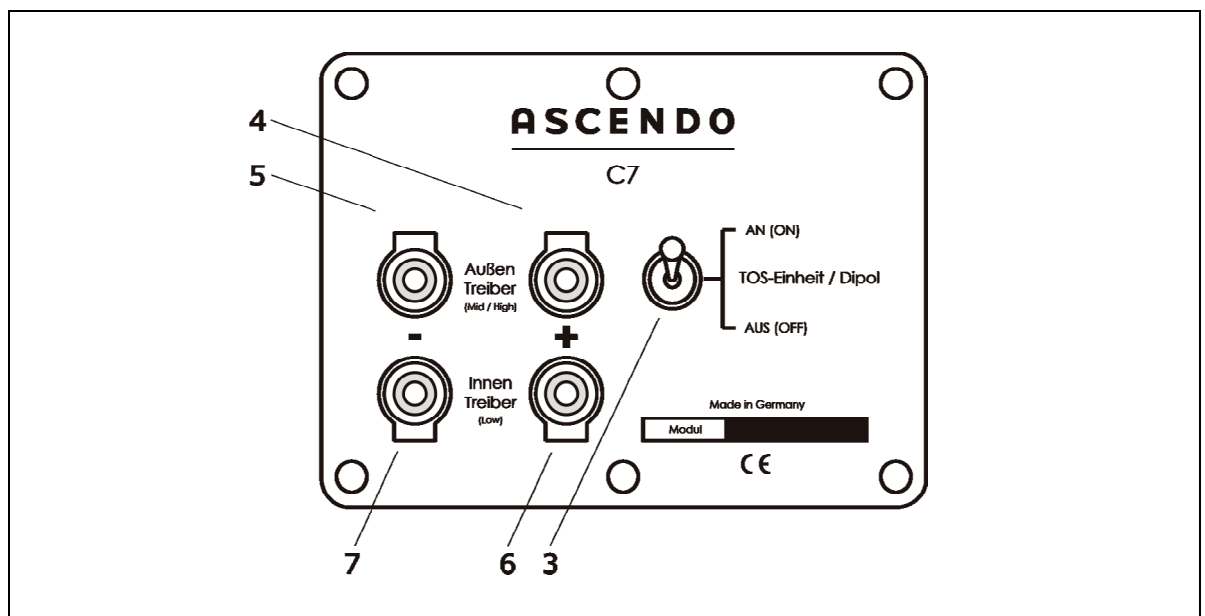

4	Plus	Outer Chas (Coax)	Mid / High
5	Minus	Outer Chassis (Coax)	Mid / High
6	Plus	Inner Chassis	Low
7	Minus	Inner Chassis	Low
3	Switch	TOS Unit / Dipole On - Off	

The C7 can be connected as follows:

- single-wired: one cable-pair from power-amp to outer chassis (4+5) unit, one bridge-cable pair from outer chassis (4+5) to inner chassis (6+7).
- bi-wired: one cable-pair from power amp to outer chassis (4+5), one from the power amp to inner chassis (6+7). This is recommended by ASCENDO.
- bi-amped: one cable-pair from separate amps outer chassis (4-5) and inner chassis (6+7)

Take care of connecting always the plus (red) terminal of your power amp with the plus (4 + 6 / red) terminal of the speaker.

5. TOS-Unit

The conception of C7 utilizes a switch-able backfiring TOS-Unit. This Unit optimizes spectral inhomogeneous decay times.

The system offers two complementary modes of operation:

Switch (3) in position AN (Dipole)

- 4-way dipole diversity with TOS - Unit

Switch (3) in position AUS (Hemisphere)

- One-Point-Source with homogenous hemisphere diversity

6. Cleaning

Clean the enclosure and stand of the ASCENDO C7 with a dry and soft cloth. Don't use water or other chemicals. Don't touch the tweeter and the woofer.